



Self-leveling suspension, servicing

Air spring dampers and level regulation, troubleshooting

Condition	Verification	Possible causes	Corrective action
		Leakage at air spring damper	Repair air spring damper front ⇒ 40-10, Front air spring shock absorber, servicing rear ⇒ 42-11, Rear air spring shock absorber, servicing
"Very slow" pressure loss Vehicle sits crooked after an extended time	Observe level over extended period of time, and identify leakage with commercially available leak-detection spray ⇒ Topic 43-2	Leakage at air lines	Service air line ⇒ 43-2, Air line, servicing
		Leakage at residual pressure retaining valve	Replace air spring damper front ⇒ 40-7, Air spring damper, removing and installing rear ⇒ 42-8, Air spring damper removing and installing
Vehicle sitting crooked No leakage exists	Perform guided fault finding with vehicle diagnosis, testing and information system VAS 5051	Vehicle level sensor defective	Replace vehicle level sensor front ⇒ 40-7, Left and right front level control system sensor G78 / G289 removing and installing, vehicles with strut suspension rear ⇒ 42-4, Left and right rear level control system sensors G76/G77, removing and installing
Vehicle sits too high, can not be lowered	1.) Check if vehicle has sufficient ground	Vehicle has bottomed out	

	clearance		
	2.) Check air lines and line routing	Air line plugged, pinched, or frozen	Service pinched air lines, ⇒ 43-2, Air line, servicing Blow pressurized air through frozen and plugged air lines
	3.) Perform guided fault finding with the vehicle diagnosis, testing and information system VAS 5051	Exhaust valve or air spring valve not functioning	
	4.) Perform steps 1-3, and if no problems are found up to this point, the residual pressure retaining valve no longer permits air to escape (is stuck)	Residual pressure retaining valve no longer permits air to escape (stuck)	Replace residual pressure retaining valve front ⇒ 40-10, Residual pressure valve, removing and installing rear ⇒ 42-11, Residual pressure valve, removing and installing
Vehicle sits low and can not be raised or can only be raised very slowly	5.) Perform guided fault finding with vehicle diagnosis, testing and information system VAS 5051	Examine electrical system relays, connectors, wiring, and fuses	
	6.) Identify leakages at accumulator with commercially available leak detection spray	Accumulator defective/leaking	Replace accumulator
		Air lines or connections to accumulator defective/leaking	Service air line ⇒ 43-2, Air line, servicing
	7.) Perform guided fault finding with vehicle diagnosis, testing and information system VAS 5051	Exhaust valve defective/leaking/open	Replace air supply unit ⇒ 43-2, Air supply unit with solenoid valve block, removing and installing
	8.) Identify leakages at air supply unit using commercially available leak-detection spray	Air supply unit malfunctioning	Service air supply unit ⇒ 43-2, Air supply unit, servicing
			Replace air supply

	9.) Perform steps 5-8, and if no problems are found up to this point, the air supply unit is defective	Air supply unit defective	unit ⇒ 43-2, Air supply unit with solenoid valve block, removing and installing
"Quick" pressure loss	Vehicle level is uneven, and when attempting to change vehicle level, air escaping from defective air spring is audible	Air spring is defective	Repair air spring damper front ⇒ 40-10, Front air spring shock absorber, servicing rear ⇒ 42-11, Rear air spring shock absorber, servicing
		Air line is torn off	Service air line ⇒ 43-2, Air line, servicing
Insufficient dampening	Test drive, and adjust dampening level while driving. The dampening must change noticeably when driving over uneven roadways. Also pay attention to "rumbling noises"	Dampening adjustment valve defective	Repair air spring damper front ⇒ 40-10, Front air spring shock absorber, servicing rear ⇒ 42-11, Rear air spring shock absorber, servicing
		Shock absorber worn	Repair air spring damper front ⇒ 40-10, Front air spring shock absorber, servicing rear ⇒ 42-11, Rear air spring shock absorber, servicing Clean air line system 1)

Perform the following test under these conditions:

- The vehicle must be cold and can not be moved during test
- The room temperature should be between 10 - 30 °C and remain steady
- The vehicle should be sitting on a level surface

- Start engine.

- On vehicles with front information display control head

control module J523 move vehicle level to High and then to Normal.

- Turn off engine.
- Separate connector from level control system control module J197 , so that the level control is disabled.

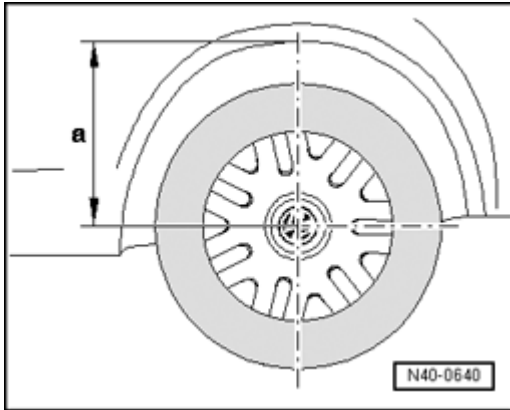

- Measure vehicle height at all four wheels.
- After 2 hours, measure vehicle height again and compare this measurement - **a** - with first measurement.

If the vehicle is sitting crooked, a leak is present at the suspension with the greatest difference between the first and second measurement.

- Check the affected air spring damper and corresponding air line with commercially available leak detection spray in the following order:

If no deviation is determined after 2 hours, the measurement must be repeated once more after 24 hours. After 24 hours, a deviation of up to 4 mm is permissible.

- Air line connections
- Residual pressure retaining valve
- Check front air spring dampers in installed position, and check rear air spring dampers when removed from vehicle.

If a shock absorber is malfunctioning, it may be possible that oil is leaking from the shock absorber into the air supply system. In order to ensure proper function of the air spring system, it is necessary to clean the system after a malfunction or to replace more components.

- Remove affected line from air spring damper and

solenoid valve.

- Blow pressurized air through line multiple times, as well as through the line connection of solenoid valve.
- Inspect to see if shock absorber oil has leaked into solenoid valve.

If shock absorber oil is found in solenoid valve it must be replaced.

- Inspect internal line from air supply unit to solenoid valve.

If oil is found in the internal line, the air supply unit must be replaced.

Self levelling suspension component locations

Note :

- *During model year 2004, the level control system control module 7L6 907 553 A /B (200 Hz) was replaced by the level control system control module 7L0 907 553 F/* (800 Hz).*
- *With the introduction of the new control modules, the wheel acceleration sensors are discontinued, and the level control system sensors have been adapted.*
- *If a (800 Hz) control module is installed instead of a (200 Hz) control module, the level control system sensors must also be replaced. The wheel acceleration sensors remain in the vehicle to "seal" the line.*

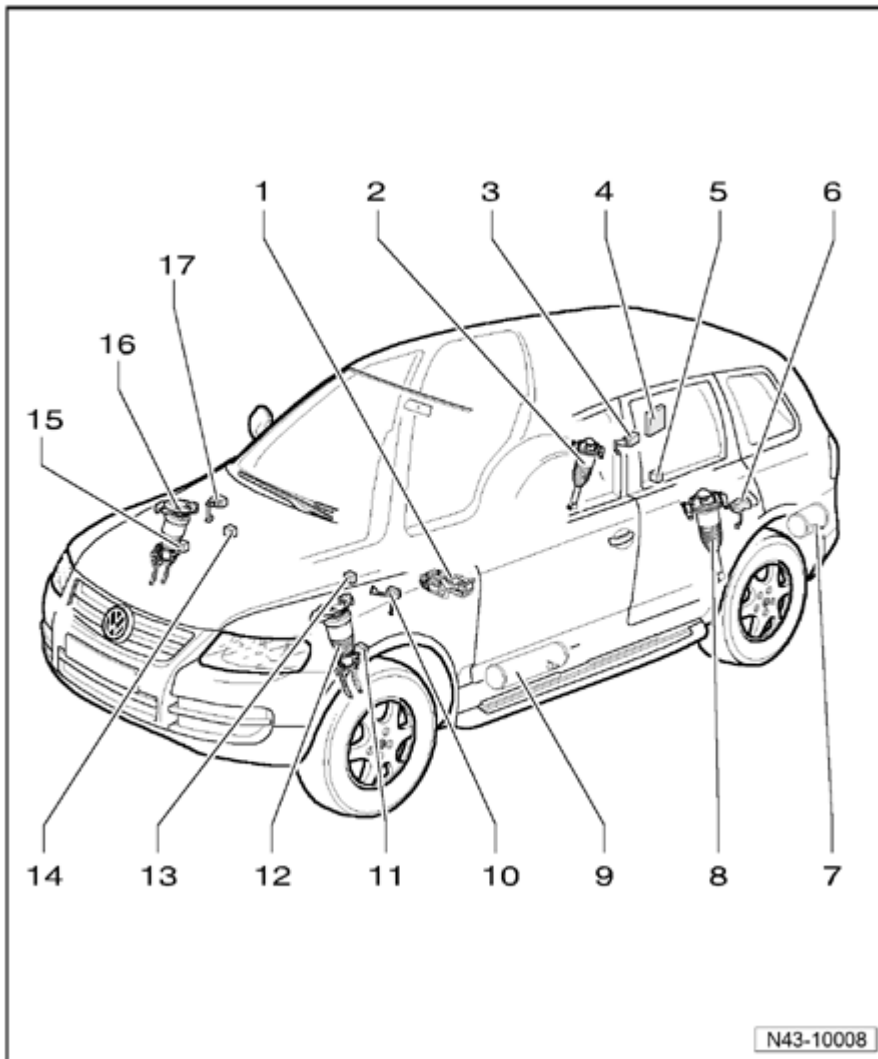

- **Air supply unit with solenoid valve block**

- Can be tested in "guided fault finding" using Vehicle diagnosis, testing and information system VAS 5051
 - Removing and installing without solenoid valve block ⇒ [43-2, Air supply unit without solenoid valve block, removing and installing](#)
 - Removing and installing with solenoid valve block ⇒ [43-2, Air supply unit with solenoid valve block, removing and installing](#)
 - Servicing ⇒ [43-2, Air supply unit, servicing](#)

- Location: Right front on underbody
- With Level Control System Compressor Motor V66
- With Level Control Pump Temperature Sensor G290
- With Level Control Pressure Sensor G291

- **Air spring damper, right rear**
 - With Right Rear Dampening Adjustment Valve N339
 - Can be tested in "guided fault finding" using Vehicle diagnosis, testing and information system VAS 5051

- **Right Rear Level Control System Sensor G77**
 - Can be tested in "guided fault finding" using Vehicle diagnosis, testing and information system VAS 5051
 - Removing and installing ⇒ [42-4, Left and right rear level control system sensors G76/G77 , removing and installing](#)
 - Location: On rear subframe

- **Level control system control module J197**
 - Can be tested in "guided fault finding" using Vehicle diagnosis, testing and information system VAS 5051
 - Removing and installing ⇒ [43-2, Level control system control module J197 ,](#)

[removing and installing](#)

- Location: In luggage compartment behind flap of ride sidewall trim
- See notes ⇒ [Topic 43-2](#)

- **Rear Body Acceleration Sensor G343**
 - Can be tested in "guided fault finding" using Vehicle diagnosis, testing and information system VAS 5051
 - Location: In luggage compartment, under the right trim in vehicle floor, beneath the cover for spare wheel

- **Left Rear Level Control System Sensor G76**
 - Can be tested in "guided fault finding" using Vehicle diagnosis, testing and information system VAS 5051
 - Removing and installing ⇒ [42-4, Left and right rear level control system sensors G76/G77 , removing and installing](#)
 - Location: On rear subframe

- **Rear accumulator**
 - Location: At left, in luggage compartment, beneath cover for spare wheel

- **Air spring damper, left rear**
 - With Left Rear Dampening Adjustment Valve N338
 - Can be tested in "guided fault finding" using Vehicle

diagnosis, testing and
information system VAS
5051

- **Front accumulator**
 - Location: Left front on
underbody

- **Left Front Level Control System
Sensor G78**
 - Can be tested in "guided
fault finding" using Vehicle
diagnosis, testing and
information system VAS
5051

 - Removing and installing ⇒
[40-7, Left/Right front level
control system sensor G78 /
G289 removing and
installing, vehicles with air
spring damper](#)

 - Location: On mounting
bracket for left front air
spring damper

- **Left Front Wheel Acceleration
Sensor G337**
 - Can be tested in "guided
fault finding" using Vehicle
diagnosis, testing and
information system VAS
5051

 - See notes ⇒ [Topic 43-2](#)

 - Location: On front left air
spring damper, opposite to
driving direction

- **Air spring damper, left front**
 - Can be tested in "guided
fault finding" using Vehicle
diagnosis, testing and
information system VAS
5051

- With Left Front Dampening Adjustment Valve N336

- **Left Front Body Acceleration Sensor G341**
 - Can be tested in "guided fault finding" using Vehicle diagnosis, testing and information system VAS 5051

 - Location: in upper left of wheel well

- **Right Front Body Acceleration Sensor G342**
 - Can be tested in "guided fault finding" using Vehicle diagnosis, testing and information system VAS 5051

 - Location: in upper right of wheel well

- **Right Front Wheel Acceleration Sensor G338**
 - Can be tested in "guided fault finding" using Vehicle diagnosis, testing and information system VAS 5051

 - See notes ⇒ [Topic 43-2](#)

 - Location: On front right air spring damper, opposite to driving direction

- **Air spring damper, right front**
 - With Left Front Wheel Acceleration Sensor N337

 - Can be tested in "guided fault finding" using Vehicle diagnosis, testing and information system VAS

5051

- **Right Front Level Control Sensor G289**

- Can be tested in "guided fault finding" using Vehicle diagnosis, testing and information system VAS 5051
- Removing and installing ⇒ [40-7, Left/Right front level control system sensor G78 / G289 removing and installing, vehicles with air spring damper](#)
- Location: On mounting bracket for right front air spring damper

Air supply unit with solenoid valve block, assembly overview

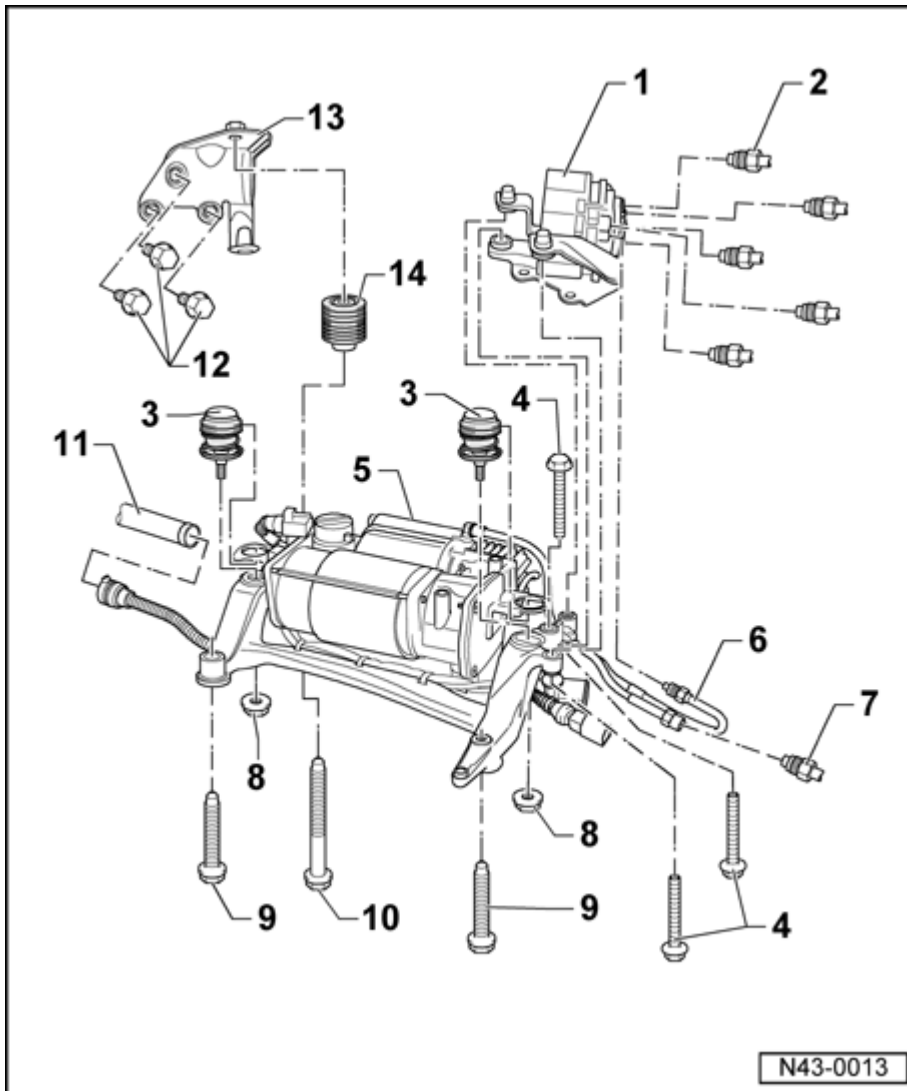

- **Solenoid valve block**

- Remove to replace air supply unit

- **Air line**

- 4 Nm
 - Clean connections before loosening
 - Air escapes when loosening connections
 - Protect threaded connections from dirt

- **Rubber bushing**

- Replace as a complete unit

- **Bolt**

- 9 Nm

- **Air supply unit**

- Removing and installing without solenoid valve block
⇒ [43-2, Air supply unit without solenoid valve block, removing and installing](#)
- Removing and installing with solenoid valve block ⇒ [43-2, Air supply unit with solenoid valve block, removing and installing](#)
- Servicing ⇒ [43-2, Air supply unit, servicing](#)

- **Air line**

- 4 Nm
- Between solenoid valve block and air supply unit
- Clean connections before loosening
- Air escapes when loosening connections
- Protect threaded connections from dirt

- **Air line**

- 4 Nm
- Between solenoid valve block and tire inflation connector
- Clean line connections before loosening
- Air escapes when loosening connections
- Protect threaded connections from dirt

- **Hex nut**
 - 9 Nm

- **Bolt**
 - 20 Nm

- **Bolt**
 - 20 Nm

- **Intake line**

- **Bolt**
 - 20 Nm

- **Bracket**

- **Rubber bushing**
 - Replace as a complete unit

Air supply unit without solenoid valve block, removing and installing

Special tools, testers and auxiliary items required

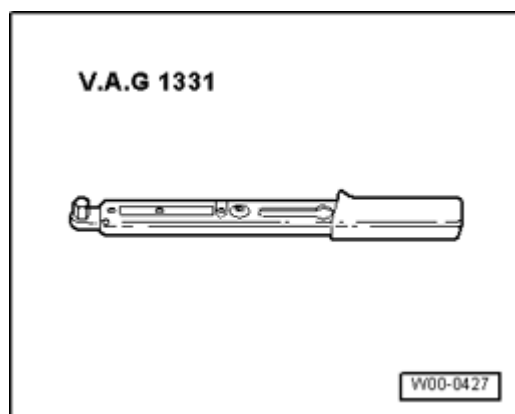

- Torque Wrench 5-50Nm VAG1331

Removing

- Remove right underbody trim

⇒ [Repair Manual, Body Exterior, Repair Group 50, Underbody trim; underbody trim - assembly overview](#)

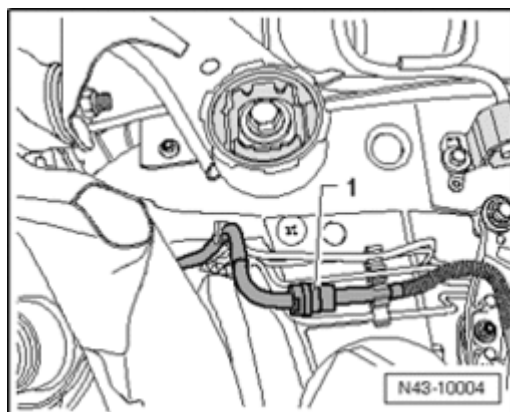

- Disconnect intake line - 1 - at clutch.

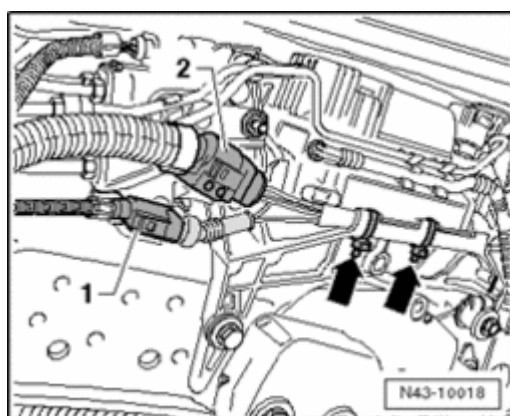

- Disconnect electrical connections - 1 - and - 2 - between air supply unit and body.

- Remove cable ties - **arrows** - .

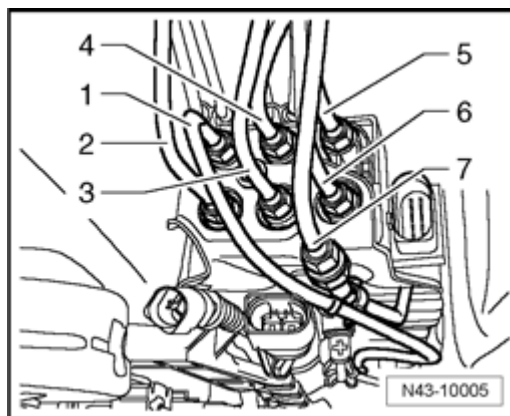

- Unscrew air line - 1 - from solenoid valve block.
Disconnect air line - 7 - at clutch.

Caution!**Air lines - 2 - and - 6 - must not be disconnected.**

- Black, internal air line between solenoid valve block and compressor
- Green, air line to right front air spring shock absorber
- Red, air line to left rear air spring shock absorber
- Violet, air line to left front air spring shock absorber
- Blue, air line to pressure reservoirs
- Yellow, air line to right rear air spring shock absorber
- Brown, air line to connection for tire inflation pressure

- Pull air lines out of bracket at underbody.

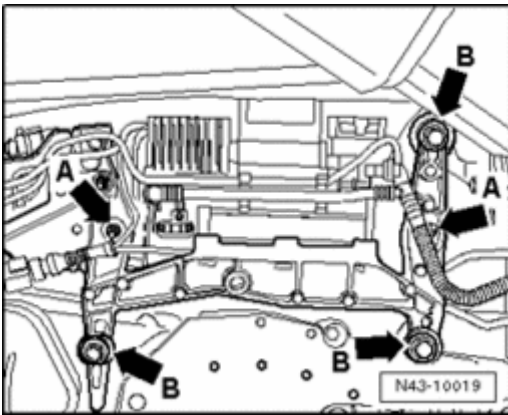

- Remove nuts - **arrows A** - for air supply unit.

- Remove bolts - **arrows B** - and secure air supply unit with bracket (second mechanic required).

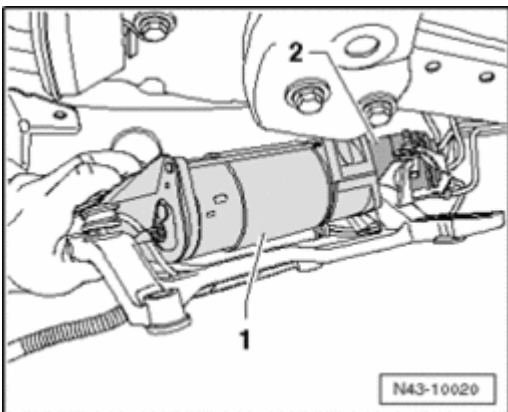

- Lower air supply unit with bracket far enough at front to remove air supply unit - **1** - .

Caution!

- **Make absolutely sure that the solenoid valve block - 2 - is moved away from underbody as little as possible.**

- **Furthermore, the air lines must not be kinked or stretched under any circumstance**

Installing

Installation is performed in the reverse order of removal.

Tightening torques	
Air lines to solenoid valve block	4 Nm
Retainer to body	20 Nm
Air supply unit to retainer	6 Nm

Air supply unit with solenoid valve block, removing and installing

Special tools, testers and auxiliary items required

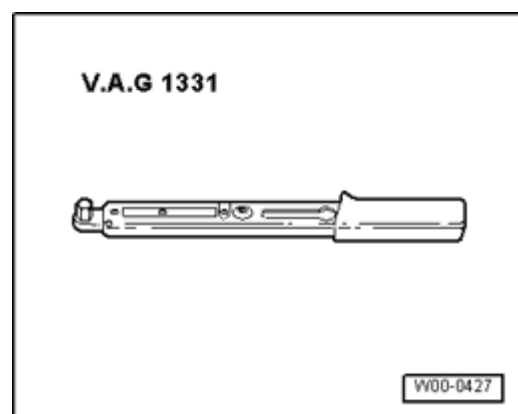

- Torque wrench V.A.G 1331

Removing

- Remove right underbody trim

⇒ [Repair Manual, Body Exterior, Repair Group 50, Underbody trim; Underbody trim - Assembly overview](#)

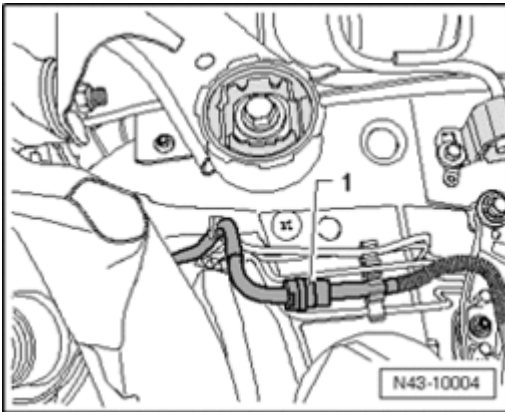

- Separate intake line - 1 - at coupling.

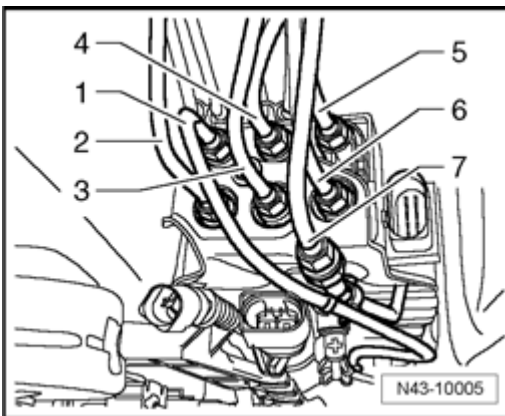

- Remove air lines - 2 - through - 6 - from solenoid valve block. Separate air line - 7 - at coupling.

- Black, internal air line between solenoid valve block and compressor
- Green, air line to right front air spring damper
- Red, air line to left rear air spring damper
- Violet, air line to left front air spring damper
- Blue, air line to accumulator
- Yellow, air line to right rear air spring damper
- Brown, air line to connection for tire inflation

- Separate electrical connections between air supply unit and body.

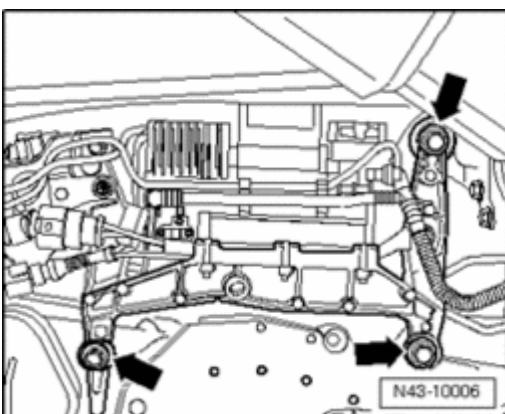

- Remove bolts - **arrows** - , and remove air supply unit.

Installing

Further installation is in reverse sequence to removal.

Tightening torques	
Air lines to solenoid valve	4 Nm
Air supply unit to structure	20 Nm

Air supply unit, servicing

Assembly overview

Note :

- *As of vehicle identification number (VIN) WVGLG77L05D072104, there is a new brown piston ring (⇒ [Item - 5 -](#)) installed.*
- *The gray piston ring, installed before VIN WVGLG77L05D072104, is replaced by the brown piston ring.*
- *Only the brown piston ring is available in the replacement kit together with Torx bolts ⇒ [Item - 2 -](#) and gasket ⇒ [Item - 4 -](#) ⇒ Electronic parts catalog "ETKA" .*

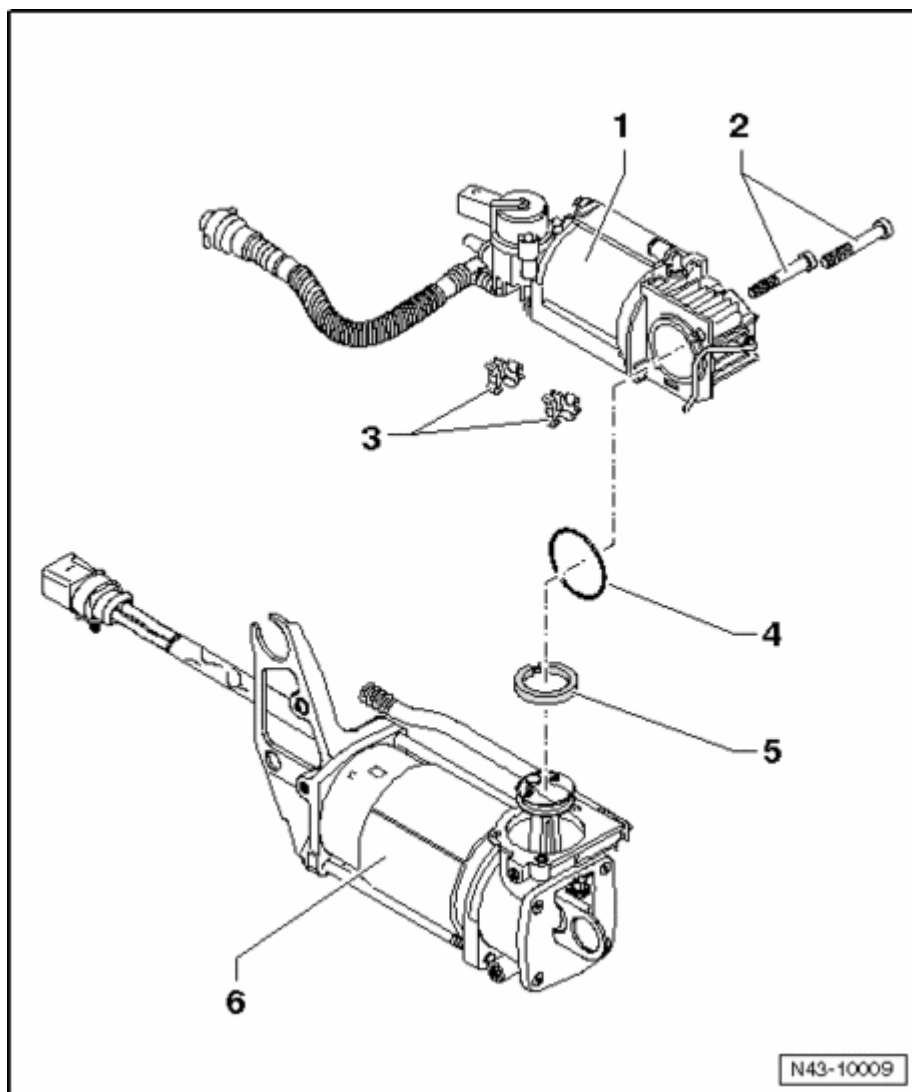

- **Air supply unit, upper part**
 - With cylinder head

- **Torx bolts T30**
 - Always replace
 - 5 Nm
 - Is included in replacement kit together with gasket ⇒ [Item - 4 -](#) and piston ring ⇒ [Item - 5 -](#) ⇒ *Electronic parts catalog "ETKA"*

- **Bracket**
 - For air line

- **Seal**

- Always replace
- Is included in replacement kit together with Torx bolts ⇒ [Item - 2 -](#) and piston ring ⇒ [Item - 5 -](#) ⇒ *Electronic parts catalog "ETKA"*

- **Piston ring**

- Replace ⇒ [43-2, Piston ring, replacing](#)
- Is included in replacement kit together with Torx bolts ⇒ [Item - 2 -](#) and gasket ⇒ [Item - 4 -](#) ⇒ *Electronic parts catalog "ETKA"*
- Observe notes ⇒ [Topic 43-2](#)

- **Air supply unit, lower part**

Piston ring, replacing

Special tools, testers and auxiliary items required

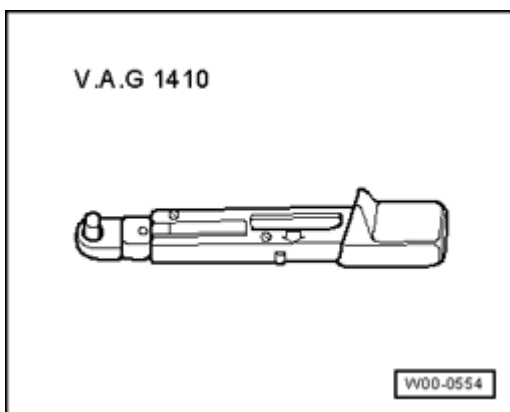

- Torque Wrech VAG1410

Observe notes ⇒ [Topic 43-2](#) .

Caution!

- **Do not clean air supply unit using chemical cleaning agent or high-pressure cleaner.**

- **Clean air supply unit using lint-free rag.**
- **Make absolutely sure that no dirt enters the open air lines/air line connections, connectors and electrical connections.**

Removing piston ring

- Remove air supply unit without solenoid valve block ⇒ [43-2, Air supply unit without solenoid valve block, removing and installing](#) .

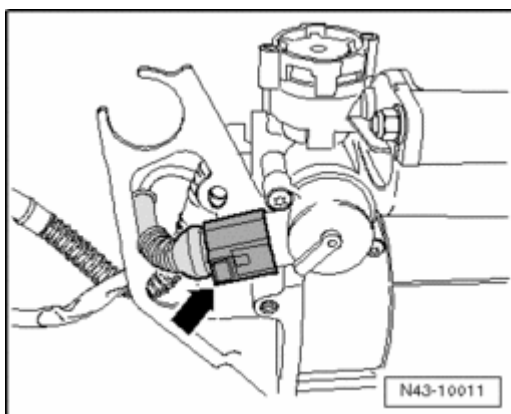

- Disengage connector - **arrow** - and disconnect it.

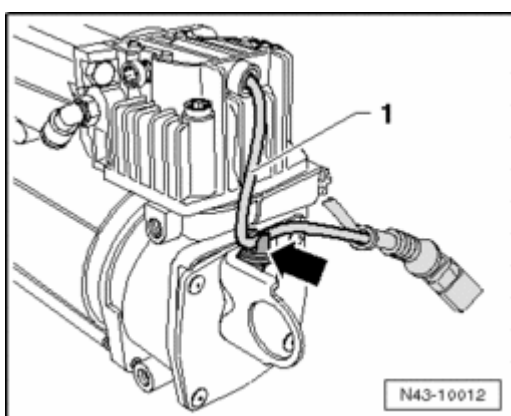

- Remove cable - **1** - from clip - **arrow** - .

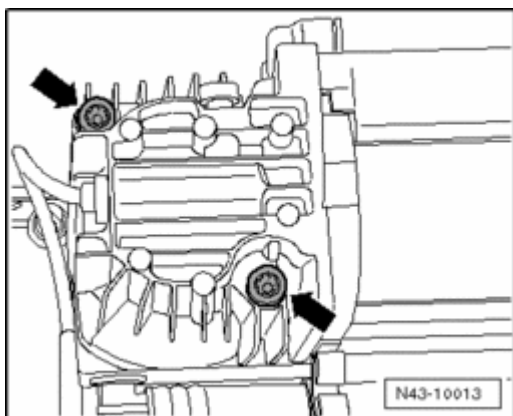

- Remove bolts - **arrows** - .

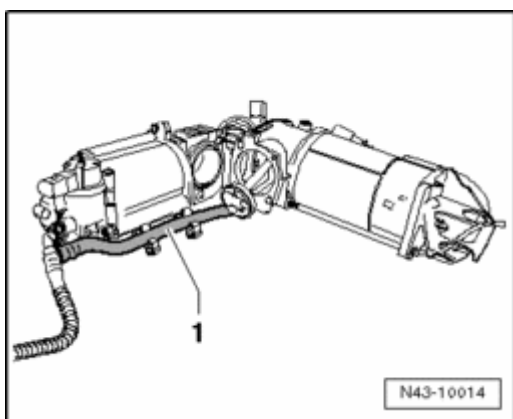

- Remove cylinder head from piston and lay aside both components next to another.

Note:

- *Make absolutely sure that the air line - 1 - is not damaged.*

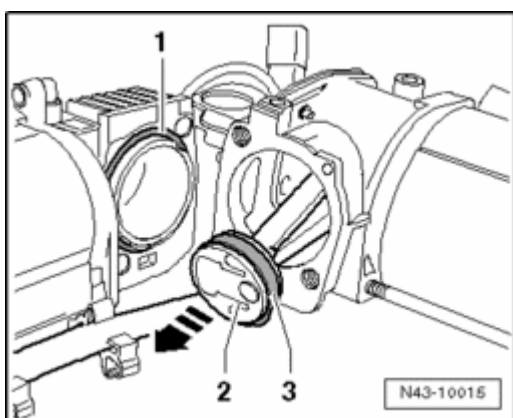

- Remove gasket - 1 - and clean contact surface on cylinder head.

- Pull piston - 2 - in - **direction of arrow** - toward TDC (Top Dead Center).

- Remove piston ring - **3** - from piston - **2** - without equipment, e.g. screwdriver.

Installing piston ring

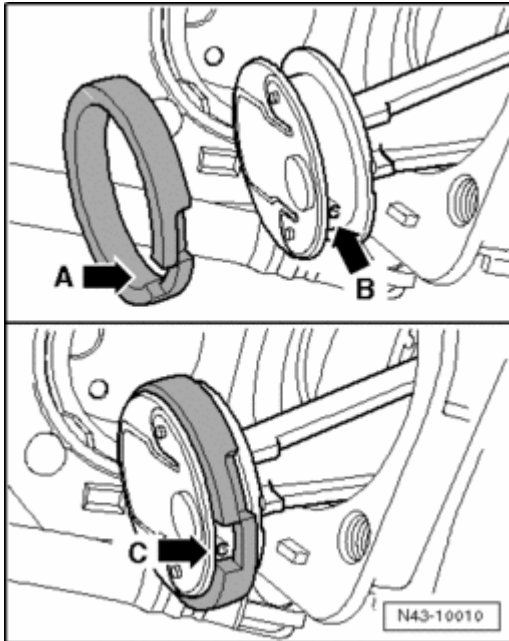

- Place new piston ring onto piston, gap - **arrow A** - on piston ring must point toward outside.

Note:

- Gap - **arrow A** - and anti-twist mechanism - **arrow B** - must align.
- Piston ring is properly installed if anti-twist mechanism is visible in gap on piston ring - **arrow C** - .
- Make sure not to overstretch piston ring.
- Check piston ring play, piston ring must be able to be easily turned in both directions within anti-twist mechanism in gap of piston ring - **arrow C** - while doing so.

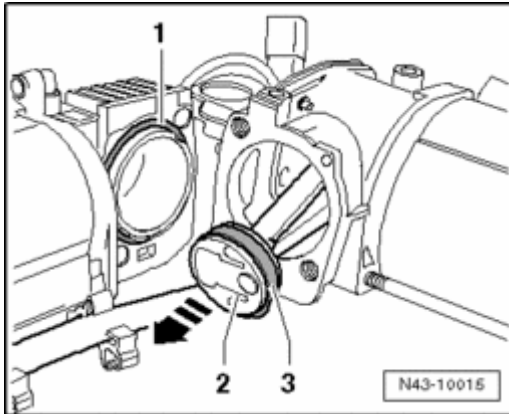

- Insert new gasket - 1 - .
- Push piston - 2 - with piston ring - 3 - opposite to - **direction of arrow** - toward BDC (Bottom Dead Center).

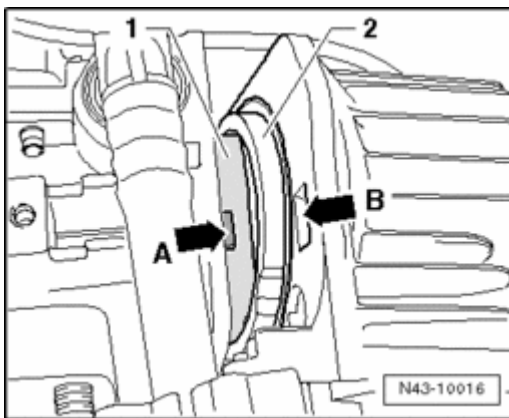

- Assemble upper and lower part, piston - 1 - must slip into cylinder head - 2 - while doing so.
- Tab - **arrow A** - must be inserted into recess - **arrow B** - . They serve as an anti-twist mechanism.

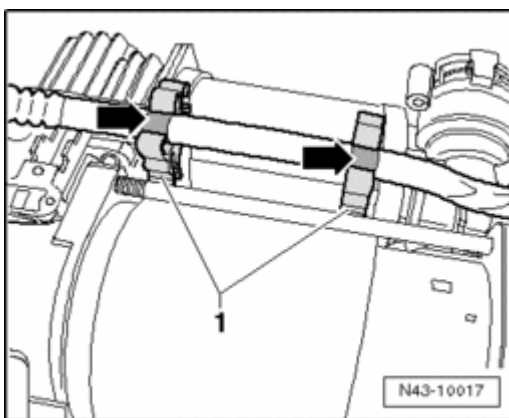

- Retainers - 1 - must be positioned between upper part and lower part and at white markings of air line - **arrows** - .

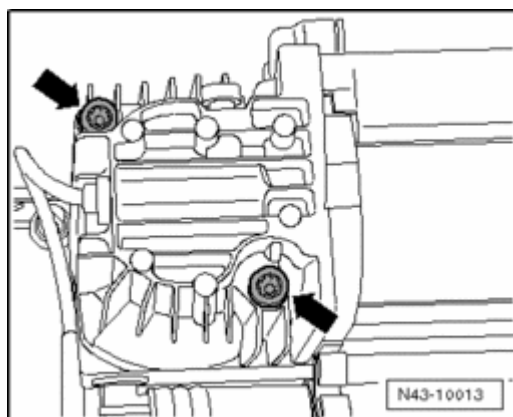

- Tighten bolts - **arrows** - to tightening torque.

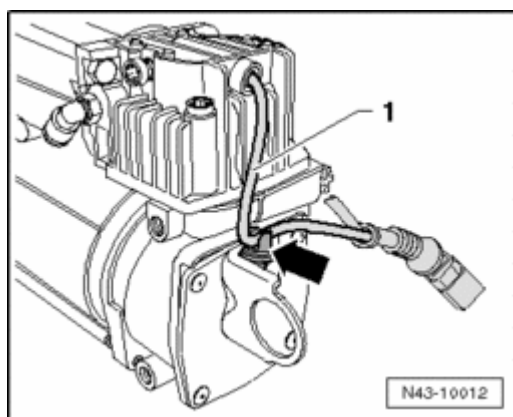

- Clip cable - **1** - in clip - **arrow** - .

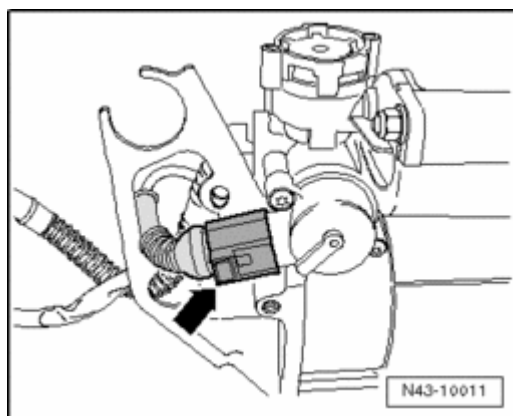

- Connect connector - **arrow** - .

- Install air supply unit ⇒ [43-2, Air supply unit without solenoid valve block, removing and installing](#) .

Tightening torque	
Upper part of air supply unit to lower part of air supply unit	5 Nm

Level control system control module J197 , removing and installing

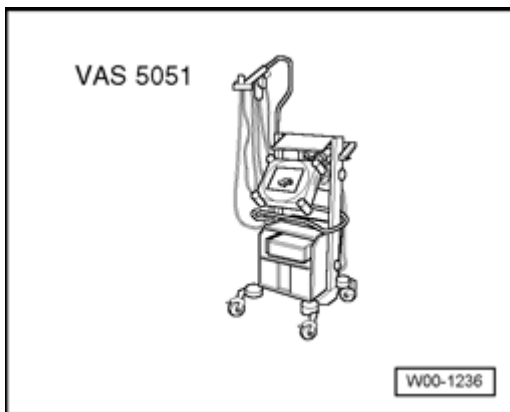
Special tools, testers and auxiliary items required

- Vehicle diagnostics, measurement and information system VAS 5051

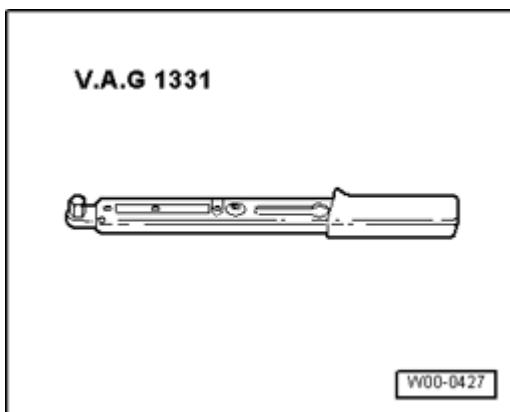

- Torque wrench V.A.G 1331

Location:

The level control system control module J197 is installed in luggage compartment behind flap on the right sidewall trim.

During model year 2004, the level control system control module 7L6 907 553 A /B (200 Hz) was replaced by level control system control module 7L0 907 553 F/* (800 Hz). With the introduction of the new control modules, the wheel acceleration sensors are discontinued, and the level control system sensors have been adapted.

If a (800 Hz) control module is installed instead of a (200 Hz) control module, the level control system sensors must also be replaced. The wheel acceleration sensors remain in vehicle to "seal" the line.

- Open flap in sidewall trim and separate electrical connection between structure and control module.

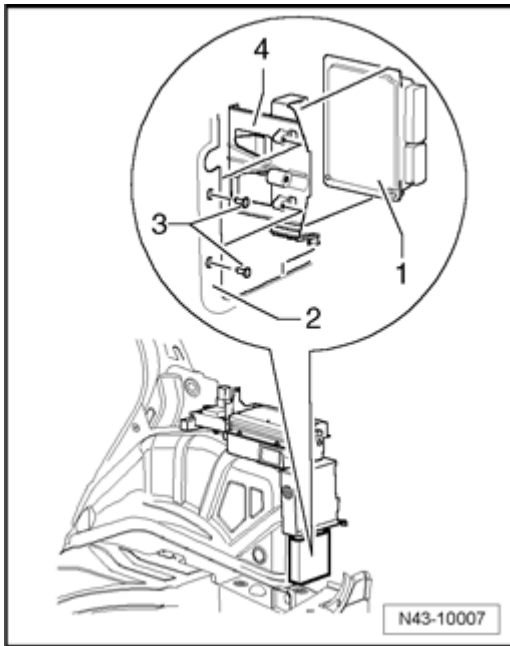

To improve clarity of installation position, the illustration shows sidewall trim removed.

- Level control system control module J197
- Wheel housing
- Bolt, 2 Nm
- Bracket

Further installation is in reverse sequence to removal.

After installation, the level control system control module J197 must be coded with the vehicle diagnosis, testing and information system VAS 5051 .

Air line, servicing

Special tools, testers and auxiliary items required

- Cutting pliers VAS 6228

Defective air lines need not be replaced complete. Partial replacement of air line is possible using a connector.

Application air line/connector see Parts Catalog.

Note:

- *The repair point must lie within an area protected from water spray, e.g. in interior or between wheel housing liner and wheel housing.*
- *The connector must be secured to body with cable ties or a cable guide.*

- *Select straight sections of line for the repair area.*

- Make a straight cut through air line using cutting pliers VAS 6228 .

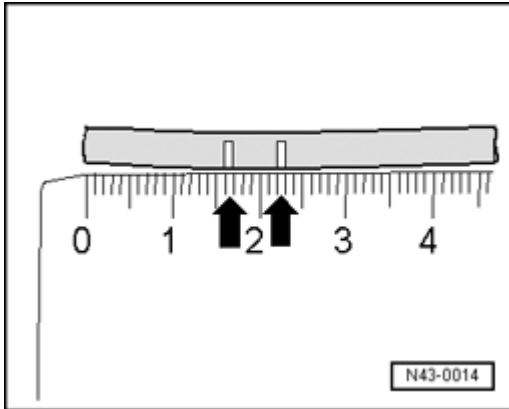

- With a felt tip pen - **arrows** - mark end of air line in vehicle and repair part.

The marks are used as a check after the repair is made.

- Route new air line along original attachment points.
- Insert both ends of lines into connector (onto limit stop).

The air lines are inserted into connector when first colored mark is no longer visible (second mark is still visible).

Self-leveling suspension, basic (default) setting

- Check basic setting of self-levelling suspension.

Connect VAS 5051 .

Then

- Press "Suspension" .
- Press "Self-leveling suspension" .
- Press "01-On Board Diagnostic (OBD)" .
- Press "Functions" .
- Press "Basic setting" .

The VAS 5051 will now display the specifications for basic setting.

- Measure the actual ride heights on vehicle ⇒ [43-2, Measuring ride height](#) .

- If the values deviate, the values measured for the self-leveling suspension must be entered into the control unit using VAS 5051 .

The self-levelling suspension control module "calculates" the values entered and then sets the vehicle at the level for the basic (default) setting.

Measuring ride height

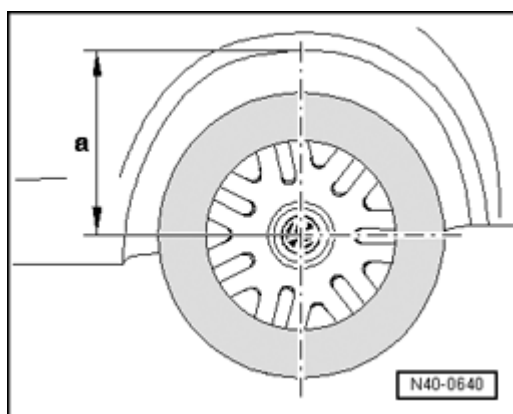

Ride height - **a** - is measured vertically from the fender or lower edge of the quarter panel to center of wheel.

The specifications are shown in Vehicle Diagnosis, Measurement and Information System VAS 5051 .